

206001 HYDROFLOOR MINI INVISA LED



Round compact ground-recessed luminaire for outdoor installation, Phospho-chromatised and polyester powder coated die-cast copper-free aluminium body and stainless steel AISI 316 frame, tempered safety glass, moulded silicone gasket, non-visible stainless steel screws. Built-in LED driver 220-240V 50-60Hz, with 4 CREE XP-G2 LED + special optics with "invisa-light" technology. IP67 rating.

Energy Label A++

- Material: high corrosion resistance die-cast copper-free aluminum body
- Coating: polyester powder coating with phosphochromating pre-finish
- NR. 4 x 1.5W CREE "XP-G2" LED
- special optics with "invisa-light" technology
- Electronic transformer 220/240V 50/60Hz included
- Stainless steel trim AISI 304
- Stainless steel screws
- Silicone rubber gasket
- Tempered safety glass.
- Max static weight resistance 2000 Kg
- Protection against impact IK09 (10 joule)
- Double M20 cable gland
- Polypropilene housing for recess included
- 1 mt. neoprene power cable included



SLIDING HOOKING SYSTEM FOR RECESSING BOX

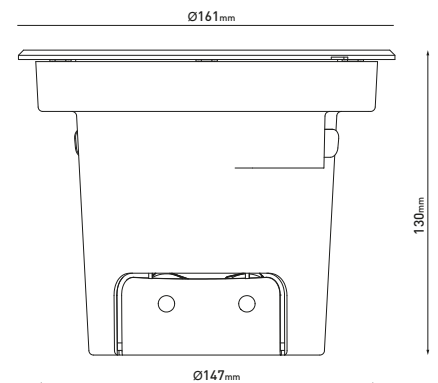

7 WATT
220-240V 50-60HZ ELECTRONIC
IP67
2,00 KG UNIT GROSS WEIGHT

LIGHT SOURCE	LED COLOR*	LIGHT BEAM OPTIONS	LUMEN OUTPUT (lm)	LUMINOUS EFFICACY (lm/w)	COLORS OPTIONS
HIGH-POWER LED	3.000°K WARM-WHITE	M 18°	595	85.00	 MATT BLACK STAINLESS STEEL (ON REQUEST)
		M 36°	565	80.71	
	4.000°K NEUTRAL-WHITE	M 18°	630	90.00	
		M 36°	598	85.43	